

## Influence of Cognitive Emotion Regulation on Psychological Well-being of Malaysian Graduates

Soheila Panahi<sup>a\*</sup>, Aida Suraya Md Yunus<sup>b</sup>, Mohammad Saeed Panahi<sup>c</sup>

\* Corresponding author: Soheila Panahi, soheilapanahi58@gmail.com

<sup>a</sup>Soheila Panahi, Consultant Office Manager, Hamadan University of Medical Sciences, Hamadan, Iran

<sup>b</sup>Faculty of Educational Studies, Universiti Putra Malaysia, 43400 Serdang, Selangor, Malaysia

<sup>c</sup>Faculty Member of Neurology, Hamadan University of Medical Sciences, Hamadan, Iran

### Abstract

<http://dx.doi.org/10.15405/epsbs.2016.05.02.6>

The purpose of this study was to examine the extent to which cognitive emotion regulation components namely self-blame, other-blame, rumination, catastrophizing, positive refocusing, positive reappraisal, planning and acceptance, influence psychological well-being among graduate students in one Malaysian university. A total of 534 graduate students, comprising of 155 males and 379 females, were selected using proportional sampling method among six faculties. Their mean age was 27 years (SD = 4.7). Descriptive analysis showed that the influence of positive reappraisal was high amongst the respondents. While, the percentages were lower in other-blame and catastrophizing. Using Structural Equation Modeling, the finding revealed that psychological well-being of graduate students influenced by planning, catastrophizing, reappraisal, other-blame, self-blame, putting into perspective, and acceptance. In conclusion, seventh strategies mentioned above explained 41% of psychological well-being of graduates students. Beside this, based on the result the model fits the data.

© 2016 Published by Future Academy www.FutureAcademy.org.uk

**Keywords:** Cognitive emotion regulation, Psychological well-being



## 1. Introduction

Psychological well-being has been depicted in relation to people's satisfaction with their life as whole (Van Tran, 1987), their involvement with existential challenges (Linley et al., 2009), maintaining depression, hopelessness and perceived stress at a low level (Miglioretti et al., 2008), quality of life (Gonzalez, Casas, & Coenders, 2007), life satisfaction, cheeriness, optimism and morale (Moore, 2006) and the sense of hopefulness, happiness and self-satisfaction (Archer, Brathwaite, & Fraser, 2005). Psychological well-being does not simply mean lack of mental disorder (Kiefer, 2008), however, it refers to the extent that people feel their lives is under their control, their activity is meaningful and valuable, and they have good interaction with other people optimistic feelings towards oneself and one's past life (Ryff, 1989).

In graduate school, one has to go through adapting themselves to the new social and educational environments. Graduate school life may be even more stressful because of the added strain of different culture values, language, and high self-expectations apart from academic demands and lack of social support systems (Constantine et al., 2005; Hyun, Quinn, Madon, & Lustig, 2007; Mori, 2000). As a result, there is a greater probability of adjustment problems, physical complaints, and psychological distress among graduate students (Constantine, Okazaki, & Utsey, 2004; Kearney, Draper, & Baron, 2005; Swagler & Ellis, 2003). Because of the transitions that graduate students have to go through, they may encounter conflicts of multiple rules, different patterns of advisory relationships, inadequate social support or financial constraints, in addition to academic stressors (Goplerud, 1980; Koeske & Koeske, 1991; Offstein, Larson, Mcneill, & Mwale, 2004; Scheinkman, 1988; Stewart, 1995; Toews, Lockyer, Dobson, & Brownell, 1993). The results of the American graduate study showed that all graduate students who were experiencing greater academic, environmental stresses had maladaptive coping skills and all graduate students with sound psychological well-being used to have more adaptive coping skills (Yang, 2010).

In this regard, Zulkefli and Baharudin (2010), Yusoff and Rahim (2010) and Zaid, Chan, and Ho (2007) have demonstrated that psychological well-being of Malaysian university students is low. According to Zulkefli and Baharudin (2010), high percentage of those with low psychological well-being has been found among students of Universiti Putra Malaysia. They also reported that approximately half of the students (52.9%) scored low on the General Health Questionnaire. Likewise, Yusoff and Rahim (2010) displayed that the prevalence of stress among Master students

in Universiti Sains Malaysia (USM) was 36.4%. They argued that, most of stressors were related to academic and performance pressure. Furthermore, prevalence of stress among undergraduate students of USM was also reported with a percentage of 29.6 (Yusoff et al., 2011). In such situation, they need to apply strategies and resources to cope with the aforementioned pressures to have both optimal level of psychological well-being and continue their academic life satisfactorily.

Regulating emotion and coping strategies can be discussed from different approaches. According to Gross (2001) and Gross and John (2003), the analysis of emotions unfolding in the course of time revealed that the initial influence of reappraisal and suppression happens at different points of emotion-generative. Particularly, reappraisal as an antecedent-focused strategy operates before the complete activation of emotion response tendencies happens. Then, it is expected to alter the temporal course of the emotional response. A response-focused strategy is suppression that interferes when the emotion is already emerging and after the response tendencies are fully produced. In addition, reappraisers experience and express greater positive emotion, whereas suppressors experience and express lesser positive emotion yet experience greater negative emotion (Gross & John, 2003). Furthermore, Sutton and Wheatley (2003) classified the emotion into positive and negative. Psychologist typically names emotions as positive when the emotion deals with pleasure or takes place while one is achieving his/her goal. Whereas negative emotions, normally involved anger and frustration.

As Lazarus and Folkman (1984) put it in this way, coping is the 'constantly changing cognitive and behavioral efforts to manage specific external and internal demands that are appraised as taxing or exceeding the resources of the person's capacity (p. 141). Lazarus (1993) introduced two methods of coping, that is, problem-focused coping (i.e., decreasing the distress through changing oneself or ones environment) and emotion-focused coping (i.e., applying cognitive coping strategies to alter the meaning of stressful events and lower the subsequent emotional distress). These two methods of coping are adaptive and the best influential approach depends on the type of stressful situation. In addition, it is apparent that emotional responses to stressful events can be controlled through making use of cognitive coping strategies (de Ridder & Schreurs, 2001; Folkman & Moskowitz, 2004).

Although the mentioned classification of coping strategies is a generally accepted and widely used concept and many coping instruments are dealing with it, that leads to a major conceptual

problem, i.e. that the classification of coping into the two groups of problem-focused and emotion-focused is not the only dimension in which coping strategies can be divided. A rather new scale, the Cognitive Emotion Regulation Questionnaire (CERQ; Garnefski et al., 2001) was suggested to evaluate cognitive coping related to emotion regulation.

Garnefski and Kraaij (2007) suggested that cognitive emotion regulation refers to the cognitive approach of consciously monitoring and regulating the information that lead to emotional arousal. The CERQ is different from previous tools since it consists of a wider set of cognitive coping procedures. Particularly, the CERQ evaluates nine cognitive coping approaches: (1) self-blame; (2) blaming others; (3) acceptance; (4) refocus on planning (refers to the required steps that need to be taken to deal with the situation); (5) positive refocusing (focus on positive experiences); (6) rumination; (7) positive reappraisal (attributing some kinds of positive importance to the event); (8) putting into perspective (lowering the significance of the event); and (9) catastrophizing.

The researchers consider self-blame, blaming others, rumination, and catastrophizing as maladaptive coping styles, while acceptance, refocus on planning, positive refocusing, positive reappraisal, and putting into perspective are regarded as adaptive coping styles (Garnefski et al., 2001). So, this study aimed to measure cognitive coping strategies of graduate students. Some researches that were recently conducted have confirmed the fact that there is a firm relationship between applying these strategies and emotional problems (Garnefski et al., 2001; Garnefski et al., 2002; Garnefski et al., 2004; Kraaij, Garnefski, & Van Gerwen, 2003). According to the results of the mentioned studies, by making use of cognitive styles such as rumination, catastrophizing and self-blame individuals may be more vulnerable to emotional problems, but other cognitive styles, such as, positive reappraisal may make individuals less vulnerable.

Previous studies showed different result regarding contribution of cognitive emotion regulation components to psychological well-being. Martin and Dahlen (2005) conducted a study on predictors of cognitive emotion regulation. Participants in their study were 362 undergraduate college students (286 females, 76 males, age ranges between 18–55 years) taking psychology courses that were grouped through classroom announcements and an on-line enrollment method. Racial backgrounds were as follows: Caucasian (52.8%), African American (42.0%), Asian/Pacific Islander (1.4%), Hispanic (2.5%), and other (1.1%). Students were also given course credit for their contribution. The findings of the study showed that self-blame, rumination, catastrophizing and positive reappraisal were among the most important predictors of negative emotions. Current

findings highlight the predictive value of rumination and positive reappraisal in explaining psychological distress.

Haga, Kraft, and Corby (2009) investigated the cognitive reappraisal and expressive suppression application on 489 university students in Australia, Norway, and the United States and examined the way these strategies were related to well-being processes (effect, life satisfaction and depressed mood). The participants of the study who included 140 male and 349 female psychology students ranging in age from 17 to 65 ( $M = 22.6$ ) filled in a self-administered questionnaire. Using Pearson's correlation coefficients, the increased levels of positive well-being outcomes were significantly correlated to an increased use of cognitive reappraisal.

In another study, Garnefski, Koopman, Kraaij and Ten Cate (2009) conducted a study using correlations and multiple regression analyses on the strategies of cognitive emotion regulation and psychological adjustment among adolescents. The subjects of the study were 53 adolescents who were suffering from Juvenile Idiopathic Arthritis. The age of the participants ranged from 12 to 18 with a mean age of 14 years and 3 months, and 30.2% of them were males. Finding of this investigation revealed that the most significant predictors of psychological maladjustment among adolescents with Juvenile Idiopathic Arthritis were rumination and catastrophizing. Obviously, the participants made use of maladaptive cognitive emotion regulation strategies in reaction to Juvenile Idiopathic Arthritis as a chronic disease.

Harrington and Loffredo (2010) discovered rumination as a predictor of well-being. The participants of the study were 121 college students who replied an online version of the Rumination–Reflection Questionnaire, the Satisfaction with Life Scale and the Psychological Well-Being Scale. A multivariate regression analysis showed that rumination was the highest negative predictor of well-being. Moreover, the results showed that there is a significant relationship between depressive symptomatology and the cognitive strategies of self-blame, rumination, positive reappraisal, putting into perspective and catastrophizing (Garnefski, Boon, & Kraaij, 2003). Thus, the purpose of this study was to investigate that to what extent cognitive emotion regulation components namely; self-blame other-blame, rumination, catastrophizing, positive refocusing, positive reappraisal, planning and acceptance, affect psychological well-being of graduate students in a Malaysian university.

## 2. Methodology

A descriptive correlational research design was utilized in this study. In order to select the sample size, proportional sampling method is applied to select participants from six faculties namely; Agriculture, Science, Engineering, Modern languages, Educational Studies, Medicine. In this study, the authors used Cognitive Emotion Regulation questionnaire in order to collect data Ryff's (1989) Psychological Well-Being scale was adapted. It is one of the most widely applied scales to assess psychological well-being. This scale is divided into to six different components which were analyzed independently. The response required is based on six point Likert scale, from strongly disagree (score = 1) to strongly agree (score = 6). Each subscale has 14 items, making a total of 84 items (See Table 1). The dimensions analyzed were:

- i. Autonomy: evaluates independence, self-determination, and an internal locus of control.
- ii. Environmental mastery: evaluates the individuals' ability to handle and control complicated situations.
- iii. Personal growth: assesses the individuals' needs for realizing their potentials.
- iv. Positive relationships: evaluates the individuals' ability to trust, love, and make deep relationships with other people.
- v. Purpose in life: evaluates the extent to which individuals are straightforward and assesses their sense of goals in life.
- vi. Self-acceptance: evaluates the positive attitudes that individuals hold toward themselves.

The Cognitive Emotion Regulation Questionnaire or CERQ (Garnefski et al., 2001) is a multidimensional questionnaire which is suggested to figure out the cognitive coping strategies that individuals apply after going through a negative situation or event. Unlike other coping scales that did not distinctly differentiate individuals' thoughts and their real practices, this scale investigates individuals' thoughts after going through a troublesome event. The privilege of CERQ is that it is easy to conduct and there are 36 items included in this self-report questionnaire. It also includes nine different cognitive coping strategies. The CERQ can be applied to clinical and normal populations, adults and adolescents ranging from 12 years and up. Actually, two kinds of cognitive processes exist, that is, unconscious cognitive processes (e.g. projection or denial) and conscious cognitive processes (Self-blame, acceptance, rumination, positive refocusing, planning, positive reappraisal, putting into perspective catastrophizing, and other-blame).

Before conducting this study, a pilot study was done in order to test the reliability coefficients of the questionnaires in the novel circumstance. A total of 45 graduate students were randomly selected from six faculties (Agriculture, Science, Engineering, Modern languages, Education, Medicine). To evaluate the internal consistency of the six psychological well-being subscales, Cronbach's alpha coefficients were calculated for all variables. After removing two items from autonomy, one item from personal growth, and one item from purpose in life, the Cronbach's alpha coefficients were found to be between 0.70 to 0.75 as suggested by Kline (2005). Likewise, to assess the internal consistency of the nine CERQ scales, Cronbach's alpha coefficients were computed for all research groups. It was concluded that the alpha coefficients of the different subscales among graduate students ranged between .76 to .89 (in all cases well over .70 and in many cases even over .90). Acceptance and rumination has the lowest Cronbach's alpha values respectively, while the highest values are for planning and appraisal, respectively.

### 3. Result

The sample size of this study was 534 graduate students. Their age ranges between 19 to 45 years, 155 male (29%) and 379 female participants (71%). Their mean age was 27 years (SD = 4.7). Participants were randomly selected from six faculties (Agriculture, Science, Engineering, Modern Languages, Educational Studies, and Medicine) and they were of different semesters through their study programs. Regarding marital status, 379 (71.2%) of the students were married and 151 (28.3%) were single. 202 (37.8%) were working and 332 (62.2%) were registered as full time students. In addition, participation in the study includes composition of the three main races in Malaysia (Malay (380), Chinese (87) and Indian (63)).

#### 3.1 Levels of Respondents' Cognitive Emotion Regulation

Table 1 below shows the respondents' level of cognitive emotion regulation. The level of cognitive emotion regulation dimensions was divided into three levels, namely: low, moderate, and high, based on construct. The findings revealed that majority of the respondents were at the moderate level in the six dimensions of self-blame (47.4%), rumination (52.8%), put into perspective (52.6%), refocusing (46.6%) planning (43.3%), and acceptance (50.6%). On the other hand, the percentages were lower in other-blame (52.4%) ( $M = 10.1$ ,  $SD = 3$ ) and catastrophising (52.1%) ( $M = 9.48$ ,  $SD = 3.27$ ). However, majority of the respondents displayed the highest level in positive reappraisal (65.4%) ( $M = 16.15$ ,  $SD = 3.34$ ).

**Table1.** Distribution of Level of Cognitive Emotion Regulation

Variables	Range	Frequency	Percentage	Mean	SD
Self-blame	Low (4-9.33)	173	32.4%	11.39	3.11
	Moderate (9.34-14.66)	253	47.4%		
	High (14.67-19.99)	108	20.20%		
Other-blame	Low (4-9)	280	52.4%	10.01	3
	Moderate (9.1-14)	203	38%		
	High (14.1-19)	51	9.6%		
Rumination	Low (4.9.33)	69	12.9%	13.05	3.10
	Moderate (9.34-14.66)	282	52.8%		
	High (14.67-19.99)	183	34.3%		
Catastrophising	Low (4.9.33)	278	52.1%	9.84	3.72
	Moderate (9.34-14.66)	187	35%		
	High (14.67-19.99)	69	12.9%		
Putting into perspective	Low (4.9.33)	119	22.3%	12.50	3.28
	Moderate (9.34-14.66)	270	50.6%		
	High (14.67-19.99)	145	27.1%		
Refocusing	Low (4.9.33)	97	18.2%	13.67	3.35
	Moderate (9.34-14.66)	249	46.6%		
	High (14.67-19.99)	188	35.2%		
Positive reappraisal	Low (5-10)	40	7.5%	16.15	3.34
	Moderate (10.1-15)	145	27.2%		
	High (15.1-20)	349	65.4%		
Planning	Low (8-12)	84	15.7%	15.92	3.01
	Moderate (12.1-16)	233	43.6%		
	High (16.1-20)	217	40.6%		
Acceptance	Low (6-10.67)	52	9.7%	14.41	3.07
	Moderate (10.68-15.34)	270	50.6%		
	High (15.35-20.01)	212	39.7%		

### 3.2 Cognitive Emotion Regulation Components as Predictors of Psychological Well-being

The standardized regression revealed that the psychological well-being of the respondents was influenced by six dimensions of cognitive emotion regulation in a descending order, as follows:



planning ( $\beta = .33$ , CR = 7.001,  $P < 0.001$ ), catastrophizing ( $\beta = -.21$ , CR = -4.795,  $P < 0.001$ ), reappraisal ( $\beta = .19$ , CR = 3.822,  $P < 0.001$ ), self-blame ( $\beta = -.16$ , CR = -3.927,  $P < 0.001$ ) other blame ( $\beta = -.15$ , CR = -3.723,  $P < 0.001$ ), and acceptance ( $\beta = -.14$ , CR = -3.579,  $P < 0.001$ ) (see Table2).

**Table 2.** Regression Weight of Cognitive Emotion Regulation Components on Psychological Well-being

Hypothesized relationships		Unstandardized regression weight Estimate (B)	S.E.	Standardize d regression weight ( $\beta$ )	C.R.	P
<b>T.wb</b>	<-- Self-blame	-.084	.021	-.163	-3.927	.000**
<b>T.wb</b>	<-- Other-blame	-.084	.022	-.153	-3.723	.000**
<b>T.wb</b>	<-- Catastrophizing	-.094	.020	-.214	-4.795	.000**
<b>T.wb</b>	<-- Putting into perspective	.024	.021	.047	1.138	.255
<b>T.wb</b>	<-- Reappraisal	.093	.024	.189	3.822	.000**
<b>T.wb</b>	<-- Planning	.176	.025	.326	7.008	.000**
<b>T.wb</b>	<-- Acceptance	-.075	.021	-.142	-3.579	.000**
<b>T.wb</b>	<-- Rumination	.037	.022	.068	1.672	.095
<b>T.wb</b>	<-- Refocusing	.023	.020	.049	1.149	.250

Note: Twb = Total psychological well-being; .000\*\* =  $P < .001$

### 3.3 Goodness of Fit

As illustrated in Figure1, the following results were obtained: Goodness of Fit index (GFI) = .99, Comparative Fit Index (CFI) = .99, normed fit index or NFI = .99, root mean square residual (RMR) or standardized RMR = .025 and root mean square error of approximation (RMSEA) = .06. In this relation, it was determined that P value = 0.014, DF = 4,  $\chi^2$  (CMIN) = 12.53 and CMIN/df = 3.13. Based on this, it is concluded that the model fits the data.

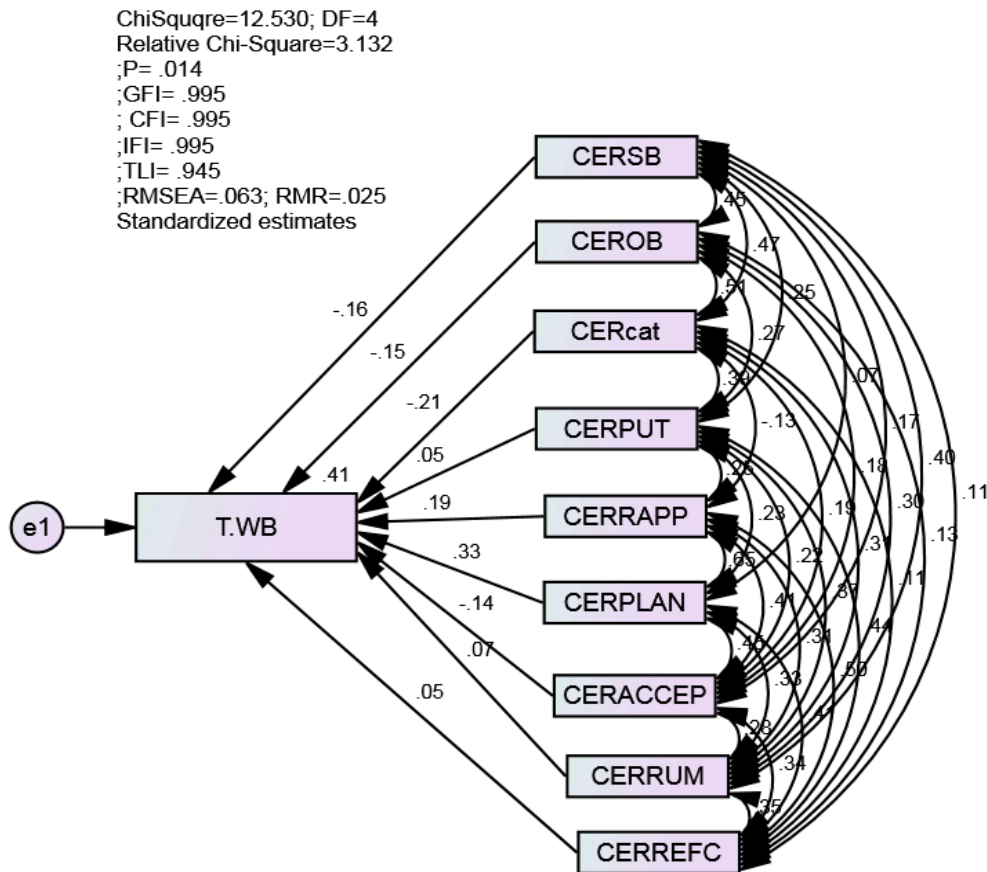

**Note:** T.WB = Total psychological well-being, LOGPHYW = Walking, CERSB = Self-blame, CEROB = Other-blame, CERCAT = Catastrophising, CERPOT = Putting into perspective, CERRAPP = Reappraisal, CERPLAN = Planning, CERACCEP = Acceptance, CERRUM = Rumination, CERREFC = Refocusing

**Fig. 1** A Structural Model for the Contributions of Cognitive Emotion Regulation Components on Psychological Well-being

**4. Discussion**

*4.1 Respondents' Cognitive Emotion Regulation Types*

In term of the respondents' level of cognitive emotion regulation, the findings showed that the highest score is for positive reappraisal and the lowest for catastrophising and other-blame. As observed, adults made more use of the majority of cognitive coping strategies. Exceptions are for the positive refocusing as an adaptive strategy as well as catastrophising and other-blame as

maladaptive strategies, the use of which seems to somehow decrease in adulthood (Garnefski, Legerstee, et al., 2002). The findings of a study by Haga et al. (2009) seem to suggest that the use of strategies varies not only within cultures but also across cultures. Similarly, the authors viewpoint is that, the respondents are educated people and suppose to use more adaptive strategies (positive reappraisal, planning and so on) than maladaptive strategies (catastrophizing, self-blame, and other blame). This finding, however, is contrary to Li and Lambert's (2007) finding, that planning is the most commonly used coping strategy. The participants of Li and Lambert (2007) study were predominantly women suffering from breast cancer, who were examined for their behavioral coping strategies in terms of their condition. Since their case is unlike the present study, thus their planning strategy was not only made, but also applied to reduce the negative consequences of their diseases. Since making plans does not always mean that they are carried out, one may also think about making plans but not actually acting on it (Perte&Miclea, 2011). Nevertheless, in the current study, the respondents were academic students (as normal people) measured based on their cognitive coping strategies. According to Garnefski et al. (2001), as a behavioral problem-focused coping, planning requires taking direct actions. In this regard, Carver et al. (1989) have demonstrated that using planning as a coping strategy is positively related to measures of optimism and self-esteem and negatively related to anxiety. Thus, it can be argued that planning may be more applicable in a behavioral way than a cognitive manner, regardless of them being academic or non-academic.

#### *4.2 Cognitive Emotion Regulation Components as Predictors of Psychological Well-being*

Based on this finding, psychological well-being of graduate students is influenced by planning. One obvious way in which planning may contribute to psychological well-being is through facilitating goal attainment (MacLeod, Coates, & Hetherington, 2008). There is emerging empirical evidence that planning for goals is strongly linked to well-being. High levels of well-being have been found to be associated with high levels of planning for personal goals (MacLeod & Conway, 2005; Nezlek, 2001; Prenda & Lachman, 2001).

Martin and Ahlen (2005) expressed that responses such as catastrophizing and self-blame are associated with reporting more emotional problems, whereas responses such as positive reappraisal are related to fewer problems in adolescence. In addition, it has been shown that catastrophizing was the most significant predictor of psychological maladjustment in adolescents (Garnefski et al., 2009). In the present research, positive reappraisal has significant positive effect on psychological

well-being, which is supported by previous studies (see Martin, Dahlen; 2005); Haga et al., 2009). One of the best predictors of well-being was self-blame as indicated by Li and Lambert (2007). Furthermore, other-blame had significant and negative contribution to psychological well-being of the respondents. In this regard, Garnefski, Baan, and Kraaij (2005) found positive relationships between other-blame and psychological distress. Findings of the present study also revealed that acceptance influenced psychological well-being of the respondents negatively. According to Garnefski and Kraaij (2006), depression scores and acceptance have a positive relationship; the acceptance scores of a sample of psychiatric adults were rather high. Wilson (1996) mention that the reason behind these results could be explained by the theory that differentiates between the passive form of acceptance, i.e. resignation to negative events and active form of acceptance, i.e. the self-admiration process. In this study, the passive form of acceptance is considered as a commonly considered form of negative adjustment with poor results (Wilson, 1996). Another study illustrated that the acceptance subscale might not be the appropriate form of adaptive coping (Garnefski et al., 2001). There was some support for the acceptance adaptive role which has positive correlation with both adaptive anger control and stress, and anger suppression and depression. The reason could be as a result of the acceptance subscale which includes some elements, and there are some degrees of hopelessness in items such as “I think I have to take it as it is and I cannot change it.” Thus, only in special cases, acceptance can be adaptive. However, acceptance might be a moderate character among the nine cognitive emotion regulation constructs, for example in comparison with catastrophizing and positive reappraisal, which are more extreme feature of maladaptive and adaptive strategies. Then, it supposedly fluctuates among adaptive and maladaptive strategies, based on characteristics of society and respondents.

## **Conclusion**

In this study, high score was found in strategy of positive reappraisal. Among nine components of cognitive emotion regulation, planning was found to be a strong predictor of psychological well-being. Besides this, catastrophizing, reappraisal, other-blame, self-blame, putting into perspective and acceptance had effective contribution in psychological well-being of graduates. In conclusion, 41% of psychological well-being of graduates was explained by mentioned strategies above. Therefore, types of coping strategies should be given more consideration by educational authorities. If improvements is made in their policy it may possibly enhance the capability of the students to apply appropriate strategies in various situations in order to overcome their academic life challenges. To fulfill this aim, an appropriate training of the faculty is the most essential step.

Teachers and educators are able to assist students to manage their academic stress, and to teach them how to apply coping strategies during teaching and process.

## Acknowledgements

We are grateful to the lecturers who cooperated with carrying out data collection and graduate students who spent time to answer to the questionnaires in this study.

## References

- Archer, M. S., Brathwaite, F., & Fraser, H. (2005). Centenarians in Barbados: The importance of religiosity in adaptation and coping and life satisfaction in the case of extreme longevity. *Journal of Religion, Spirituality & Aging, 18*(1), 3-19.
- Carver, C. S., Scheier, M. F., & Weintraub, J. K. (1989). Assessing coping strategies: A theoretically based approach. *Journal of Personality and Social Psychology, 56*(2), 267-283.
- Constantine, M. G., Anderson, G. M., Berkel, L. A., Caldwell, L. D., & Utsey, S. O. (2005). Examining the Cultural Adjustment Experiences of African International College Students: A Qualitative Analysis. *Journal of Counseling Psychology, 52*(1), 57.
- Constantine, M. G., Okazaki, S., & Utsey, S. O. (2004). Self-concealment, social self-efficacy, acculturative stress, and depression in African, Asian, and Latin American international college students. *American Journal of Orthopsychiatry, 74*, 230-241.
- Davies, M., Stankov, L., & Roberts, R. D. (1998). Emotional intelligence: In search of an elusive construct. *Journal of Personality and Social Psychology, 75*(4), 989.
- de Ridder, D., & Schreurs, K. (2001). Developing interventions for chronically ill patients: is coping a helpful concept? *Clinical Psychology Review, 21*(2), 205-240.
- Folkman, S., & Moskowitz, J. T. (2004). Coping: Pitfalls and promises. *Annual Review of Psychology in the Schools, 55*, 745-774.
- Garnefski, N., Boon, S., & Kraaij, V. (2003). Relationships between cognitive strategies of adolescents and depressive symptomatology across different types of life event. *Journal of Youth and Adolescence, 32*(6), 401-408.
- Garnefski, N., Koopman, H., Kraaij, V., & ten Cate, R. (2009). Brief report: Cognitive emotion regulation strategies and psychological adjustment in adolescents with a chronic disease. *Journal of adolescence, 32*(2), 449-454.
- Garnefski, N., & Kraaij, V. (2007). The Cognitive Emotion Regulation Questionnaire: Psychometric features and prospective relationships with depression and anxiety in adults. *European Journal of Psychological Assessment, 23*, 141-149.
- Garnefski, N., Kraaij, V., & Spinhoven, P. (2001). Negative life events, cognitive emotion regulation and emotional problems. *Personality and individual differences, 30*(8), 1311-1327.
- Garnefski, N., Legerstee, J., Kraaij, V., van den Kommer, T., & Teerds, J. (2002). Cognitive coping strategies and symptoms of depression and anxiety: A comparison between adolescents and adults. *Journal of adolescence, 25*(6), 603-611.
- Garnefski, N., Teerds, J., Kraaij, V., Legerstee, J., & van den Kommer, T. (2004). Cognitive emotion regulation strategies and depressive symptoms: differences between males and females. *Personality and individual differences, 36*(2), 267-276.
- Gonzalez, M., Casas, F., & Coenders, G. (2007). A complexity approach to psychological well-being in adolescence: Major strengths and methodological issues. *Social Indicators Research, 80*(2), 267-295.

- Goplerud, E. N. (1980). Social support and stress during the first year of graduate school. *Professional Psychology, 11*(2), 283.
- Gross, J. J. (2001). Emotion regulation in adulthood: Timing is everything. *Current Directions in Psychological Science, 10*(6), 214-219.
- Gross, J. J., & John, O. P. (2003). Individual differences in two emotion regulation processes: Implications for affect, relationships, and well-being. *Journal of Personality and Social Psychology, 85*, 348-362.
- Haga, S. M., Kraft, P., & Corby, E. K. (2009). Emotion regulation: Antecedents and well-being outcomes of cognitive reappraisal and expressive suppression in cross-cultural samples. *Journal of Happiness Studies, 10*(3), 271-291.
- Harrington, R., & Loffredo, D. A. (2010). Insight, rumination, and self-reflection as predictors of well-being. *the journal of psychology, 145*(1), 39-57.
- Hyun, J., Quinn, B., Madon, T., & Lustig, S. (2007). Mental health need, awareness, and use of counseling services among international graduate students. *Journal of American College Health, 56*(2), 109-118.
- Kearney, L. K., Draper, M., & Baron, A. (2005). Counseling utilization by ethnic minority college students. *Cultural Diversity and Ethnic Minority Psychology, 11*, 272-285.
- Kiefer, R. A. (2008). An integrative review of the concept of well-being. *Holistic Nursing Practice, 22*(5), 244.
- Kline, R. B. (2005). *Principles and Practice of SEM*. New York: The Guilford.
- Koeske, G. F., & Koeske, R. D. (1991). Student "burnout" as a mediator of the stress-outcome relationship. *Research in higher education, 32*(4), 415-431.
- Kraaij, V., Garnefski, N., & Van Gerwen, L. (2003). Cognitive coping and anxiety symptoms among people who seek help for fear of flying. *Aviation, space, and environmental medicine, 74*(3), 273-277.
- Lazarus, R. S. (1993). From psychology stress to emotions: A history of changing outlooks. *Annual Review of Psychology, 44*, 1-21.
- Lazarus, R. S., & Folkman, S. (1984). *Stress, appraisal, and coping*. New York: Springer.
- Li, J., & Lambert, V. A. (2007). Coping strategies and predictors of general well-being in women with breast cancer in the People's Republic of China. *Nursing & health sciences, 9*(3), 199-204.
- Linley, P. A., Maltby, J., Wood, A. M., Osborne, G., & Hurling, R. (2009). Measuring happiness: The higher order factor structure of subjective and psychological well-being measures. *Personality and individual differences, 47*(8), 878-884.
- MacLeod, A. K., Coates, E., & Hetherington, J. (2008). Increasing well-being through teaching goal-setting and planning skills: results of a brief intervention. *Journal of Happiness Studies, 9*(2), 185-196.
- MacLeod, A. K., & Conway, C. (2005). Well-being and the anticipation of future positive experiences: The role of income, social networks, and planning ability. *Cognition & Emotion, 19*(3), 357-374.
- Martin, R. C., & Dahlen, E. R. (2005). Cognitive emotion regulation in the prediction of depression, anxiety, stress, and anger. *Personality and individual differences, 39*(7), 1249-1260.
- Mayer, J. D., Roberts, R. D., & Barsade, S. G. (2008). Human abilities: Emotional intelligence. *Annu. Rev. Psychol., 59*, 507-536.
- Miglioretti, M., Mazzini, L., Oggioni, G. D., Testa, L., & Monaco, F. (2008). Illness perceptions, mood and health-related quality of life in patients with amyotrophic lateral sclerosis. *Journal of psychosomatic research, 65*(6), 603-609.
- Moore, M. M. (2006). *Variations in test anxiety and locus of control orientation in achieving and under achieving gifted and non gifted middle school students (Ph.D. dissertation)*.
- Mori, S. C. (2000). Addressing the mental health concerns of international students. *Journal of Counseling & Development, 78*(2), 137-144.
- Nezlek, J. B. (2001). Daily psychological adjustment and the planfulness of day-to-day behavior. *Journal of Social and Clinical Psychology, 20*(4), 452-475.
- Offstein, E. H., Larson, M. B., McNeill, A. L., & Mwale, H. M. (2004). Are we doing enough for today's graduate student? *International Journal of Educational Management, 18*(7), 396-407.
- Perte, A., & Miclea, M. (2011). The Standardization of the Cognitive Emotion Regulation Questionnaire (CERQ) ON Romanian Population. *Cognition, Brain, Behavior. An Interdisciplinary Journal, 15*, 111-130.
- Prenda, K. M., & Lachman, M. E. (2001). Planning for the future: A life management strategy for increasing control and life satisfaction in adulthood. *Psychology and aging, 16*(2), 206-216.

- Ryff, C. D. (1989). Happiness is everything, or is it? Explorations on the meaning of psychological well-being. *Journal of Personality and Social Psychology*, 57(6), 1069.
- Scheinkman, M. (1988). Graduate student marriages: An organizational/interactional view. *Family process*, 27(3), 351-368.
- Stewart, D. (1995). Developmental Considerations in Counselling Graduate Students. *Guidance & Counselling*, 10(3), 21-23.
- Sutton, R. E., & Wheatley, K. F. (2003). Teachers' emotions and teaching: A review the literature and directions for future research. A multi-componential perspective on emotions. *Educational Psychology Review*, 15(4), 327-358.
- Swagler, M. A., & Ellis, M. V. (2003). Crossing the distance: Adjustment of Taiwanese graduate students in the United States. *Journal of Counseling Psychology*, 50(4), 420.
- Toews, J. A., Lockyer, J. M., Dobson, D. J., & Brownell, A. K. (1993). Stress among residents, medical students, and graduate science (MSc/PhD) students. *Academic Medicine*, 68(10), S46-48.
- Van Tran, T. (1987). Ethnic community supports and psychological well-being of Vietnamese refugees. *International Migration Review*, 21(3), 833-844.
- Wilson, G. T. (1996). Acceptance and change in the treatment of eating disorders and obesity. *Behavior Therapy*, 27(3), 417-439.
- Yang, Y. T. T. (2010). Stress, Coping, and Psychological Well-Being: Comparison among American and Asian International Graduate Students from Taiwan, China, and South Korea.
- Yusoff, M. S. B., Liew, Y. Y., Ling, H., Tan, C., Loke, H., Lim, X., et al. (2011). A study on stress, stressors and coping strategies among Malaysian medical students. *Int J Stud Res*, 1(2), 45-50.
- Yusoff, M. S. B., & Rahim, A. F. A. (2010). Prevalence and Sources of Stress among Postgraduate medical Trainees: Initial findings. *Journal of Psychiatry*, 11, 2.
- Zaid, Z., Chan, S., & Ho, J. (2007). Emotional disorders among medical students in a Malaysian private medical school. *Singapore medical journal*, 48(10), 895.
- Zulkefly, S. N., & Baharudin, R. (2010). Using the 12-item General Health Questionnaire (GHQ-12) to Assess the Psychological Health of Malaysian College Students. *Global Journal of Health Science*, 2(1), P73.